

LLP-50H and LLP-150H

Two axis positioner with center hole

Two-axis positioners LLP-50H and LLP-150H with center hole are part of ESAB Low Load Positioning Equipment (LLPE). They are ideal for rotating and tilting lightweight workpieces.

- The speed is stepless adjustable.
- These lightweight positioners with center hole are built to meet international EN safety requirements.
- The LLP-H positioners come with a low-voltage foot pedal with Start/Stop function. For daily work, these positioners offer perfect solutions.
- The LLP-H positioners have 2-axis, motorised rotation and manual tilting.
- The LLP-H positioners includes 120 mm center hole.
- Thus, the 2-axis operation guarantees the ideal ergonomic working position.
- Mechanically and electrically the positioners have been designed for easier maintenance and a small number of spare parts as well.



Applications

- Pipe shops
- Repair

Technical data

Model	LLP-50H	LLP-150H
Max loading capacity (turning), kg	50	150
Max loading capacity (tilting), kg	50	150
Rotation speed, rpm	0 – 4.5	0 – 4.5
Tilt range, degree	± 90	± 90
Incoming supply (50Hz/1-phase), V	220	220
Control voltage, V AC	24	24
Rotation drive motor, W	60	65
Earthing, A	200	200
Table plate diameter, mm	450	450
Table hole diameter, mm	120	120
Dimensions LxWxH, mm	530x486x500	600x486x560
Cable length, foot pedal, m	3	3

Ordering information

LLP-50H	0370 250 200
LLP-150H	0370 250 201

Options

3-claw chuck	0370 250 209
--------------	--------------

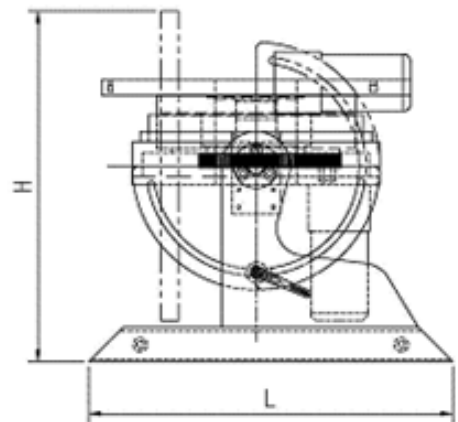
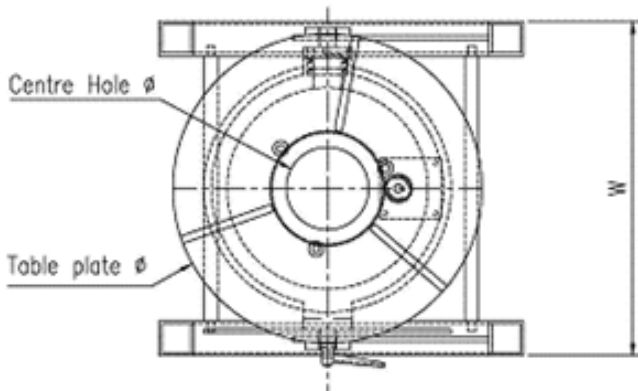

2011-03-15 / ESAB reserves the right to alter specifications without prior notice



www.esab.com

