

# RT1 – RT35

## Two-axis Positioner

**ESAB Two Axis RT1-RT35 Positioners are in fact the best answer to the problem of rotating and tilting workpieces.**

- The speed is continuously adjustable
- ESAB Positioners exceed the strictest international EN safety requirements.
- ESAB welding positioners are designed and built for tough engineering workshop conditions.
- All the positioners come with a low voltage (24V) remote control unit for all functions. For daily work, these positioners offer perfect solutions with optimized motor and gear drive sizes.
- The positioners of the RT series have 2-axis; height and rotation. Thus 2-axis operation guarantees the ideal ergonomic working position.
- The rotation speed is controlled by means of inverter. All drives are equipped with AC-motors which require less maintenance, no carbon-brush to change.
- Mechanically and electrically the positioner has been designed for easier maintenance and a smaller number of spare parts as well.



### Applications

- **Pipe shops**
- **Vessels**
- **Cladding of dish ends**
- **Fuel tanks**

## Technical data

Model		RT1	RT3	RT5	RT10	RT15	RT20	RT35
Maximum loading capacity	kg	1000	3000	5000	10000	15000	20000	35000
Rotational torque	Nm	3000	9000	15000	30000	45000	60000	105000
Tilting torque	Nm	3000	9000	15000	30000	45000	60000	105000
Rotation speed	rpm	0.16-1.55	0.1-1.0	0.08-0.82	0.048-0.48	0.1-1	0.048-0.48	0.029-0.29
Tilting range table plate	degree	0-135	0-135	0-135	0-135	0-135	0-135	0-90
Tilting speed	sec	69	80	113	177	120	177	105
Power Supply	50/60Hz/ 3-ph	380/400/415/ 440/460/480V	380/400/415/ 440/460/480V	380/400/415/ 440/460/480V	380/400/415/ 440/460/480V	380/400/415/ 440/460/480V	380/400/415/ 440/460/480V	380/400/415/ 440/460/480V
Fuses	A	10	16	18	25	40	60	60
Control Voltage	V AC	24	24	24	24	24	24	24
Table plate diameter	mm	900	1200	1500	1800	1800	2200	2800
Max welding current	A	800	800	1000	1000	1000	1000	1000
Weight	kg	700	1570	2720	4530	7100	10000	-
Dimensions	LxWxH	1230/954/ 890	1625/1070/ 1057	1720/1590/ 1227	2453/2070/ 1586	2800/2190/ 1840	3050/2400/ 1850	1940/2950/ 2600
Cable length control box	m	6	6	6	6	10	10	10

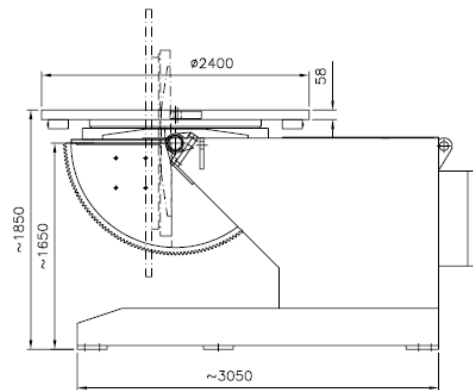
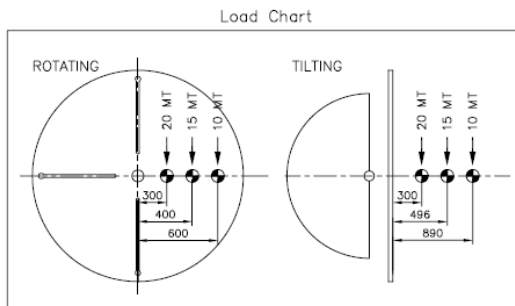

## Ordering Information

Two axis positioner RT1	0370 250 850
Two axis positioner RT3	0370 250 851
Two axis positioner RT5	0370 250 852
Two axis positioner RT10	0370 250 853
Two axis positioner RT15	0370 250 854
Two axis positioner RT20	0370 250 855
Two axis positioner RT35	0370 250 856

## Options

Foot switch	0370 250 301
-------------	--------------



[www.esab.com](http://www.esab.com)

